



Healthweigh.co.uk

Precision Medical.

Healthcare scales 2014



SHEKELHealthweigh®

www.healthweigh.co.uk



Class III EMR ready



Turier Scales have been established since 1891 and are the largest independent distributor in the UK of medical, laboratory and industrial weighing equipment.



SHEKEL HEALTHWEIGH®

Established in 1975, **Shekel Scales** has more than 35 years' experience in the design, development and manufacture of electronic scales, force measurement applications and weighing systems.

Shekel Scales offers a wide range of healthcare and fitness scales. The **Healthweigh®** collection has a unique innovative design, developed and manufactured to high professional standards.

At **Shekel**, we make sure we're always up-to-date: All of our products are EMR ready, enabling connection to hospital databases.

Healthweigh® is the scale of choice for use in hospitals, clinics and fitness centers.

	Physician Scales	03
	Titanium Indicator	08
	Special Needs Scales	09
	Neonatal & Pediatric Scales	18
	Swab Scales	21
	Ultrasonic BMI Scales	22

**Smarter Design.
Uncompromised Accuracy.**

www.healthweigh.co.uk

SHEKEL Physician Scales

Shekel's Physician Scales provide a reliable weighing process in medical centers, clinics, hospitals, fitness centers, as well as in the home.

Shekel's well-known quality meets the highest standards. Our scales are perfect for any kind of use, and are especially suitable for the professional electronic technology using environment friendly materials, and comply with European standards.

The **Healthweigh®** range is comprehensive, easy to use and visually attractive.

Physician Scale	04
Physician Scale- Waist and Floor level	05





Physician Scale

H151-00-5 (Class III);

Lightweight and slender, the **Healthweigh®** Physician Scale is a professional tool providing precision weighing information. The design patented scale is multifunctional: height and weight are indicated in a single task operation for BMI calculation. The adjustable height rod is suitable for children and adults.

Features

- Movement compensation technology
- BMI function
- Zero/Hold/Print
- 5 digit ¾" LCD/Positive FSTN
- Automatic Reweigh
- Updatable firmware
- Ports: RS232 and USB
- Optional: Bluetooth

Power

- 230v/120v input, DC 9V output
- Auto power off
- 6 X 1.5AA batteries
- Low battery indicator
- AC adapter plug storage



reddot design award
winner 2011

Technical Data

Class III	
Capacity	250kg
Graduation	0.1kg
Total Weight	12kg
Product Size	567 x 375 x 1331 mm
Platform Size	375 x 375 x 78 mm

Class III EMR
READY

An outstanding platform

Aluminum cast coat makes the scale safe and robust. The platform is wide and coated with silicone mat for patient comfort.

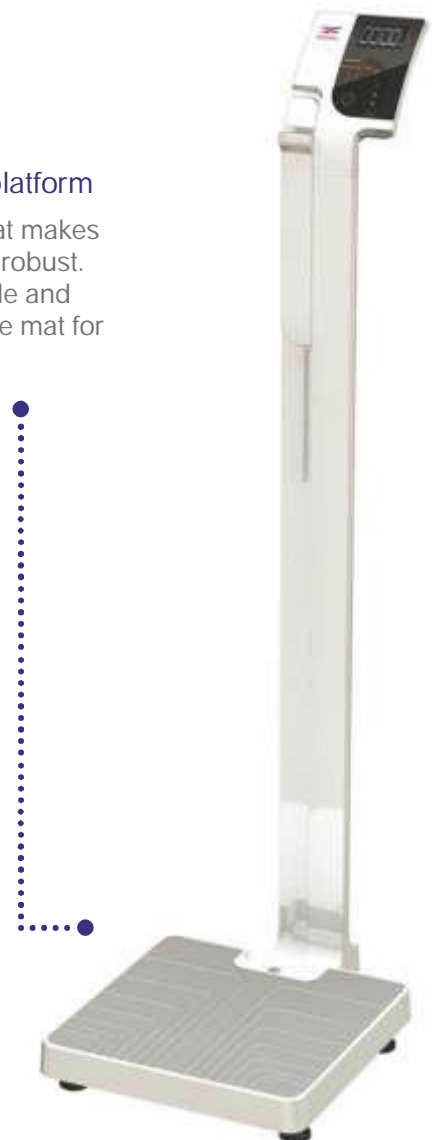

Physician Scale - Waist Level

H151-00-6 (Class III)

Lightweight and slender, **Healthweigh®** Waist Level scale is a professional tool providing precision weighing information. The scale is multifunctional: height and weight are indicated in a single task operation for BMI calculation. The waist level digital display makes it easy to read the results.

Features

- Movement compensation technology
- BMI function
- Zero/Hold/Print
- 5 digit ¾" LCD/Positive FSTN
- Automatic Reweigh
- Updatable firmware
- Ports: RS232 and USB
- Optional: Bluetooth

Power

- 230v/120v input, DC 9V output
- Auto power off
- 6 x 1.5AA batteries
- Low battery indicator
- AC adapter plug storage

Technical Data

Class III	
Capacity	250kg
Graduation	0.1kg
Total Weight	11.5kg
Product Size	567 x 375 x 1231 mm
Platform Size	375 x 375 x 78 mm

Class III EMR
READY



An outstanding platform

Aluminum cast coat makes the scale safe and robust. The platform is wide and coated with silicone mat for patient comfort.



RRP £195

Personal Floor Scale

H151-00-7 (Class III)

The **Healthweigh**® Electronic Floor Physician Scale is designed for professional needs. The large, stand-alone **Healthweigh**® Titanium Indicator has a sturdy built-in bracket for wall, table or floor mounting.

Features

- Movement compensation technology
- BMI function
- Tare/Zero/Hold/Print
- Scroll Down/Up
- 5 digit ¾" LCD/Positive FSTN
- Automatic Reweigh
- Updatable firmware
- Ports: RS232 and USB
- Optional: Bluetooth
- Healthweigh® Titanium Indicator

Power

- 230v/120v input, DC 9v output
- Auto power off
- 6 X 1.5AA batteries
- Rechargeable batteries
- Low battery indicator
- AC adapter plug storage

Technical Data

Class	III
Capacity	250kg
Graduation	0.1kg
Total Weight	6.5kg
Platform Size	375 x 375 x 78 mm

Class III EMR
READY



Physician Scale - Floor Level

H151-00-8(Class III)

Lightweight and slender, **Healthweigh®** Floor Level scale is a professional tool providing precision weighing information. The scale is multifunctional: height and weight are indicated in a single task operation for BMI calculation. The large digital display makes it easy to read the results.

Features

- Movement compensation technology
- BMI function
- Zero/Hold/Print
- 5 digit ¾" LCD/Positive FSTN
- Automatic Reweigh
- Updatable firmware
- Ports: RS232 and USB
- Optional: Bluetooth

Power

- 230v/120v input, DC 9V output
- Auto power off
- 6 X 1.5AA batteries
- Low battery indicator
- AC adapter plug storage

Technical Data

Class III	
Capacity	250kg
Graduation	0.1kg
Total Weight	6.5kg
Product Size	567 x 375 x 323 mm
Platform Size	375 x 375 x 78 mm

Class III EMR
READY

An outstanding platform

Aluminum cast coat makes the scale safe and robust. The platform is wide and coated with silicone mat for patient comfort.



RRP £140

Healthweigh[®] Titanium Indicator

The **Titanium Indicator** is specifically developed to manage professional health care weighing needs. Equipped with positive FSTN LCD, which prolongs the product's lifespan and provides easier reading, it is one of the best indicators in the industry.

The Titanium Indicator combines easy functionality and readability, with outstanding quality. Titanium **Healthweigh[®]** Indicator is available on all **Shekel Special Needs Scales** and the **Personal Floor Scale** (wall/bracket mount).

Features

- Movement compensation technology
- BMI function
- Tare/Zero/Hold/Print
- Scroll Down/Up
- 5 digit ¾" LCD/Positive FSTN
- Automatic Reweigh
- Updatable firmware
- Ports: RS232 and USB
- Optional: Bluetooth

Power

- 230v/120v input, DC 9v output
- Auto power off
- 6 X 1.5AA batteries
- Rechargeable batteries
- Low battery indicator
- AC adapter plug storage

Class III EMR
READY



SHEKEL Indicator

SHEKEL

Special Needs Scales

Healthweigh® Special Needs range responds to the needs of diverse medical sectors. Equipped with easy-to-access ramps and pressure reducing cushioned seats, this range is extremely user oriented, comfortable, easy to use, easy to operate and most important- perfectly safe.

Handrail Scale	10
Multifunction Handrail Scale	11
Wheelchair Scale with Wide Ramps and Handrail	12
Wheelchair Scale with Wide Ramps	13
Multifunction Wheelchair Scale with Two Ramps	14
Chair Scale	15
Bed Weigher	16



www.healthweigh.co.uk

Handrail Scale

H251-00-2 (Class III)

Healthweigh® Electronic Handrail Scales were designed for the bariatric practice. Its unique design and enhanced robust structure assures safety and comfort for large people. The side rails gives support to unsteady patients and movement compensation technology eliminates involuntary movement. Assembly is effortless; a pop-up patented hinge-joint sets the back rail upright in seconds and the side rails slot-in. Two heavy-duty wheels make it easy to easily move the scale.

Features

- Movement compensation technology
- BMI function
- Tare/Zero/Hold/Print
- Scroll Down/Up
- 5 digit ¾" LCD/Positive FSTN
- Automatic Reweigh
- Updatable firmware
- Ports: RS232 and USB
- Optional: Bluetooth
- Folded, Pre- assembly

Power

- 230v/120v input, DC 9V output
- Auto power off
- 6 X 1.5AA batteries
- Rechargeable battery
- Low battery indicator
- AC adapter plug storage

Technical Data

Class III	
Capacity	300kg
Graduation	0.1kg
Total Weight	22kg
Product Size	650 x 655 x 1130 mm
Platform Size	500 x 640 x 70 mm

Class III EMR
READY





Multifunction Handrail Scale

H251-00-4 (Class III)

The new Multifunction Handrail Scale has an original design. The stable, integrated seat provides the patient with a safe and comfortable weighing process. The seat can be easily lifted, thereby enabling the patient to be weighed while standing as well, supported by the robust handrail.

Equipped with an extremely robust handrail, and high capacity, Shekel's Multifunction Handrail Scale is essential for any hospital or clinic that treats heavier patients.

Features

- Movement compensation technology
- BMI function
- Tare/Zero/Hold/Print
- Scroll Down/Up
- 5 digit ¾" LCD/Positive FSTN
- Automatic Reweigh
- Updatable firmware
- Ports: RS232 and USB
- Optional: Bluetooth
- Folded, Pre- assembly

Power

- 230v\120v input, DC 9V output
- Auto power off
- 6 X 1.5AA batteries
- Rechargeable battery
- Low battery indicator
- AC adapter plug storage

Technical Data

Class III	
Capacity	300kg
Graduation	0.1kg
Total Weight	28kg
Product Size	640 x 640 x 1200 mm
Platform Size	510 x 640 x 70 mm

Class III EMR READY



Wheelchair Scale with wide ramps & handrail

H351-00-2, H351-00-3 (Class III)

Healthweigh®s new Electronic Wheelchair Scale answers both patients and carers' needs. The scale is very accessible, thanks to the exceptionally wide side ramps. Advanced movement compensation technology eliminates involuntary movement made during the weighing process and ensures exact weighing information. Manual/Automatic Tare option enables weight of wheelchair to be reduced.

Features

- Movement compensation technology
- BMI function
- Tare/Zero/Hold/Print
- Scroll Down/Up
- 5 digit ¾" LCD/Positive FSTN
- Automatic Reweigh
- Updatable firmware
- Ports: RS232 and USB
- Optional: Bluetooth
- Folded, Pre- assembly

Power

- 230v/120v input, DC 9V output
- Auto power off
- 6 X 1.5AA batteries
- Rechargeable battery
- Low battery indicator
- AC adapter plug storage

Technical Data

Class III	
Capacity	300kg
Graduation	0.1kg
Total Weight	
H351-00-2	33kg
H351-00-3	37kg
Product Size	
H351-00-2	750 x 780 x 1150 mm
H351-00-3	1250 x 940 x 1150 mm
Platform Size	
H351-00-2	1000 x 940 x 70 mm
H351-00-3	800 x 780 x 70 mm

Class III EMR
READY



H351-00-2 with one wide ramp



H351-00-3 with two wide ramps



The scale has patented hinge joint for simple assembly and can be folded and transported on two heavy duty wheels.



Wheelchair Scale with wide ramps

H351-00-7, H351-00-8 (Class III)

Healthweigh® Wheelchair Scales are equipped with easy-to-access wide ramps. Advanced movement technology eliminates involuntary movement made during the weighing process and ensures exact weighing information. The wheelchair scale is available with either one or two wide ramps and comes equipped with the **Healthweigh®** Titanium Indicator.

Features

- Movement compensation technology
- BMI function
- Tare/Zero/Hold/Print
- Scroll Down/Up
- 5 digit ¾" LCD/Positive FSTN
- Automatic Reweigh
- Updatable firmware
- Ports: RS232 and USB
- Optional: Bluetooth

Power

- 230v\120v input, DC 9V output
- Auto power off
- 6 X 1.5AA batteries
- Rechargeable battery
- Low battery indicator
- AC adapter plug storage

Technical Data

Class III	
Capacity	300kg
Graduation	0.1kg
Total Weight	
H351-00-7	29kg
H351-00-8	33kg
Product Size	
H351-00-7	750 x 870 x 82 mm
H351-00-8	1250 x 940 x 82 mm
Platform Size	
H351-00-7	1000 x 940 x 70 mm
H351-00-8	800 x 780 x 70 mm

Class III EMR
READY



H351-00-7 with one wide ramp



H351-00-8 with two wide ramps

Multifunction Wheelchair Scale with two ramps

H351-00-4 (Class III)

Equipped with an integrated seat, Shekel's new Electronic Multifunction Wheelchair Scale extends the concept of multifunctionality. The accessible scale allows patients to be weighed while sitting on the safe and stable seat, using their own wheelchair, or even while standing supported by the robust handrail.

Features

- Movement compensation technology
- BMI function
- Tare/Zero/Hold/Print
- Scroll Down/Up
- 5 digit ¾" LCD/Positive FSTN
- Automatic Reweigh
- Updatable firmware
- Ports: RS232 and USB
- Optional: Bluetooth

Power

- 230V\120v input, DC 9V output
- Auto power off
- 6 X 1.5AA batteries
- Rechargeable battery
- Low battery indicator
- AC adapter plug storage

Technical Data

Class	III
Capacity	300kg
Graduation	0.1kg
Total Weight	43.2kg
Product Size	1250 x 740 x 1250 mm
Platform Size	800 x 780 x 70 mm

Class III EMR
READY



- In spite of its robustness and versatility, the scale can be easily folded





Chair Scale

H551-00-1 (Class III)

The new Chair Scale with its patented design maintains **Shekel's** well-known reputation for reliability and uncompromising precision. With a few smart changes, **Shekel** has created the ideal ergonomic patient product. All of a patient's care needs, including safety, comfort, caregiver's use and maintenance, are met. The compact package design ensures the most cost efficient shipping method.

Features

- Movement compensation technology
- BMI function
- Tare/Zero/Hold/Print
- Scroll Down/Up
- 5 digit ¾" LCD/Positive FSTN
- Automatic Reweigh
- Updatable firmware
- Ports: RS232 and USB
- Optional: Bluetooth

Power

- 230v\120v input, DC 9V output
- Auto power off
- 6 X 1.5AA batteries
- Rechargeable battery
- Low battery indicator
- AC adapter plug storage

Technical Data

Class III	
Capacity	300kg
Graduation	0.1kg
Total Weight	18kg
Product Size	630 x 850 x 965 mm
Seat Size	430 x 420 x 80 mm

Class III EMR
READY

Ergonomic patient-oriented design:

The armrests can be lifted separately, allowing the patient to slide from his chair to the chair scale while leaning on the prone armrest. The footrest can be folded as well for easier access.



Bed Weigher

RRP £1495



WPT/4B 500C

Class III
Capacity 500kg
Graduation 0.2kg

WPT/4B bed scales are precise weighing instruments verified for class III use for patients who are bed bound. Four weighing modules are connected by cables to allow placing the scale pads under the bed. Lifting of the bed is simple using the supplied jack, designed for wheels between 100mm and 200mm. Rs232 port

BED SCALES



RRP £1595



The beams are designed to weigh patients in lying position. The distance between beams is adjustable up to 2.5 meters so it's appropriate for different types of bed.

The indicator is equipped with backlit LCD, powered either by mains adaptor or batteries.

Light construction (single beam mass 8kg) for ease of transport.

Easy access onto the beams (beam height approx. 18mm)

- Capacity 300kg
- Graduation 0.1kg
- Tare range -300kg
- Com port Rs232

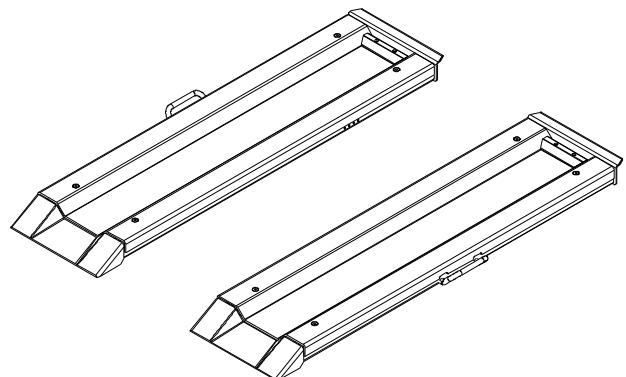
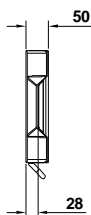
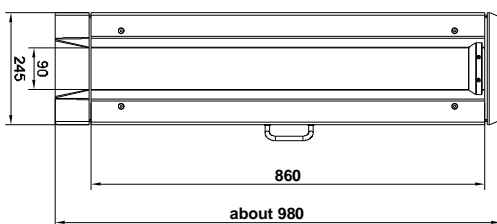
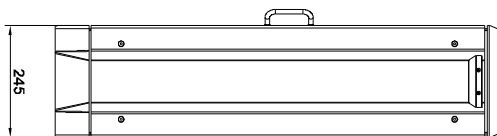

SHEKEL Neonatal & Pediatric Scales

Weight gain is an essential sign of good health in newborns. **Shekel** Scales are ergonomically designed for the newborn and growing baby.

Shekel advanced technology is so precise that our scales are integrated into warmers and incubators used to sustain premature babies.

Unique movement compensation technology provides 100% accuracy, even when baby moves during weighing.

We have over 30 years' experience in manufacturing neonatal scales.

Shekel – quality and precision for your baby.



www.healthweigh.co.uk



Neonatal Scales

H651-00-XX (Class III)

Healthweigh® newly designed Neonatal Scales feature advanced technology for precision weighing of newborn and growing babies. Removable upper tray allows for weighing in a standing position. Optional digital measuring rod for accurate calculation of baby's length.

- Tray scale for infants
- Removable tray for weighing in standing position
- Scale with optional digital measuring rod



Features

- Movement compensation technology
- Tare/Pre-set Tare
- Zero/Hold
- Scroll Up/Down
- Clear/Enter
- kg only
- Updatable firmware
- RS232 Port and USB Port

Power

- 230v/120v input, DC 9V output
- Auto power off
- Rechargeable battery
- Low battery indicator
- Dry battery 6 x AA

Technical Data

Class III	Dual Range	Single Range
Capacity	0-6kg 6-12kg	20kg
Graduation	±2g ±5g	±5g
Total Weight	7kg	7kg
Product Size	600 x 430 x 145 mm	600 x 430 x 145 mm

Class III EMR
READY

BABY SCALES

RRP £205



WPT 6/15DC and WPT 10/20DC are precise electronic scales manufactured in class III and designed for weighing infants. The weighing pan is made of Owispol polystyrene and the display is in backlit LCD.

Each scale is powered by mains (230V/11V AC). The indicator also has batteries (6xAA - an alternative Power source for the scale).

PUE C/31 is the standard indicator for this scale.



	WPT 6/15D	WPT 10/20D
Max capacity	6/15 kg	10/20 kg
Readability	2/5 g	5/10 g
Tare range	-15 kg	-20 kg
Working temperature	0° - +40 °C	
Interface	RS 232	
Power supply	230V / 11V AC or 120V / 11V AC and 6xAANiMH accumulator	
Display	LCD (backlit)	

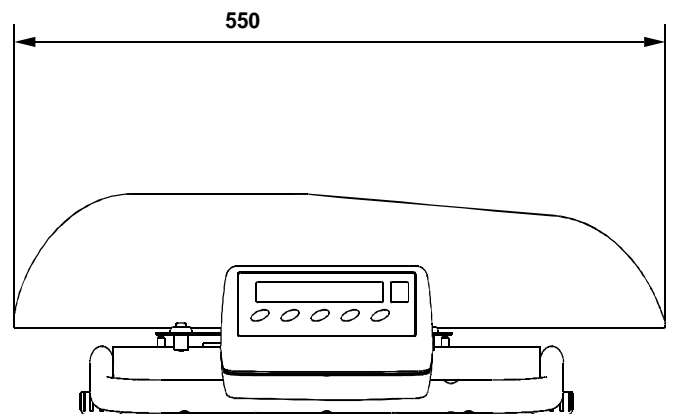
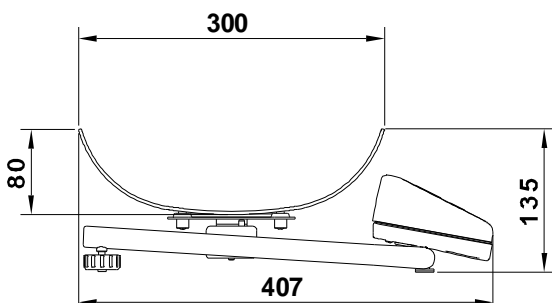

RRP 5000g x 1g £99
3000g x 0.2g £155

Swab Scale -

Construction 304 grade stainless steel.

Lightweight and slender, the swab scale is a professional tool providing precision weighing information. The scale has multiple weighing units.

The large digital display makes it easy to read the results.

Features

- Auto shut off selectable
- Zero Tracking
- Low battery indicator
- 1/5000, 1/15000 division options
- Easy calibration
- Auto backlight selectable
- lb:oz, g,kg,lb,oz selectable
- Counting pieces function

Technical Data

Capacity	3000g / 5000g
----------	---------------

Graduation	0.2g / 1g
------------	-----------

Net Weight	2.2kg
------------	-------

Plate Size	165 x 175mm
------------	-------------

Power

- 230v input, DC 10V output
- Auto power off
- 6 X 1.2v rechargeable batteries / mains adaptor
- Low battery indicator



Ultrasonic Physician BMI Scale

H120-00-4

Innovative Healthweigh® Electronic Ultrasonic height measuring device determines height and weight simultaneously, and relays an integrated result with BMI value.

Results appear graphically showing average, high and low BMI at the time of weighing which gives an immediate indication of health risk factor. The scale rod unfolds for easy assembly.

Features

- Movement compensation technology
- Automatic BMI calculation
- Updatable firmware
- Measures room temperature
- RS232 Port x 2 and USB
- Optional BT, TCP/IP

Technical Data

Non-Class 	
Capacity	250kg / 550lb
Graduation	0.1kg / 0.2lb
Total Weight	15kg / 33lb
Product Size	525 x 380 x 240 mm 21" x 15" x 25"
Platform Size	380 x 370 x 80 mm 15" x 14.65" x 3.15"

Power

- 230v input, DC 12V output



SHEKEL Quality

Shekel Standards

Shekel adheres to the highest standards of measurements and compliance.

- ISO 9001:2008 certified
- ISO 13485:2005 certified
- ISO 17025:2005 certified
- Certificate Of Quality System For EC Declaration Of Type Conformity Directive 90/384/EEC Precision Class III governing non-automatic weighing instruments (NAWI) and are calibrated accordingly
- RoHS Compliant Directive 2002/95/EC
- Safety/EMC EN60601-1 for medical devices



(90/384/EEC)



Class III

ISO 13485



ISO 9001:2008



ISO-17025:2005

Shekel Design Patents

- Physician Scale is registered under European Community Registered Design #001269708-001; the Design Patent is pending in the US (and elsewhere).
- Weighing Chair is registered under European Community Registered Design #001269708-002; the Design Patent is pending in the US (and elsewhere).

www.healthweigh.co.uk



Turier Scales
Unit 7 Block 5
Shenstone Trading Estate
Bromsgrove Road
Halesowen
West Midlands
B63 3XB
UK

www.turierscales.co.uk

- www.healthweigh.co.uk
- sales@turierscales.co.uk
- tel +44 (0) 121 501 6880
- fax +44 (0) 121 501 6881



SHEKELHealthweigh®